

VULCANO FTI-300 | FTI-400

“Vulcano” Industrial Sieve shaker is ideal for small production runs of between 5 and 75 kg of product, liquids or solids, depending upon the type.

Manufactured with AISI 304 stainless steel (or AISI 316, under request), is equipped with an engine with eccentric masses that generates a three-dimensional movement which makes the sieving of the product as easy as possible. The adjustment of the masses allows to regulate the behavior of the product in the mesh and the speed of sieving.

- > Sieves without outlet and bottom with or without product outlet.
- > Is not suitable for working in areas with explosive atmospheres.
- > Quick close “Easy Press” (optional).
- > Supports up to 5 sieves of Ø300 or Ø400 mm.

The standard system for fixing the sieves is composed of threaded stainless bars, bakelite knobs and a methacrylate ring, open or closed.



GENERAL DIMENSIONS

(mm)	FTI-300	FTI-400
ØA	300	400
ØB	402	500
ØC	480	575
D	1032	1175
E	361,5	398
ØF	100	100
G	74 adjustable	

INCLUDES:

- > Sieve Shaker
- > Methacrylate ring
- > Threaded closing system
- > User Manual
- > CE declaration of conformity

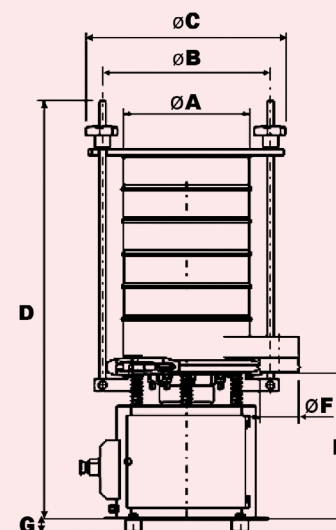

TECHNICAL FEATURES						
	Voltage (V)	Freq. (Hz)	(r.p.m)	(A)	Power (kW)	Weight (Kg)
FTI-300	400/460	50/60	1500	0.41	0.17	52
FTI-400				0.6	0.30	57